

ASME Bladder Accumulator

207,310, 345 & 420 bar

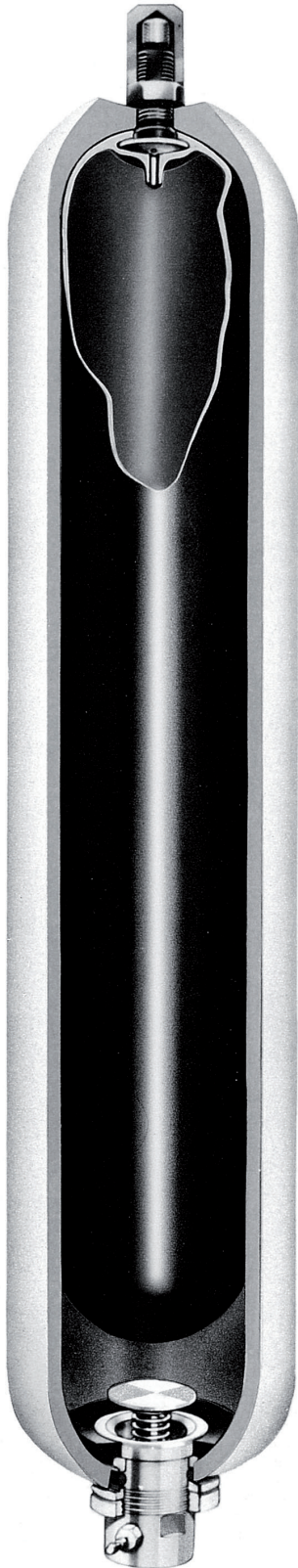

Specification

Shell

Oil Service - seamless shell, designed and manufactured to ASME VIII Division 1'U' coded.

Label

With assembly specification and installation details.

Witness hydro-pneumatic pressure tests

All our accumulator shells are pressure tested. An additional hydro-pneumatic pressure test on the complete accumulator can be undertaken with or without a specific inspection authority as an optional extra.

Material Certification

Available on request for all major pressure loaded parts.

Finish

One coat primer paint as standard. Special paints available.

Bladder

Totally enclosed construction with an extensive range of elastomers available. See Bladder information for further details.

Fluid Port Assembly

Integral high-flow port and poppet valve assembly with an anti-extrusion ring. For options see overleaf.

Safety

All gas-loaded accumulators are pressurised vessels and it is recommended that safety consideration be given to the application in which they are used. A relief valve should always be fitted to the hydraulic system with the option of a burst disc to protect the accumulator. If there is a fire risk in the vicinity of the accumulator, then a fusible/eutectic plug should be fitted. See Installation and Servicing data sheet for information regarding installation of accumulators.

Accessories

A complete range of accumulator accessories are available from OLAER Fawcett Christie.

Spare Parts

Available on request.

Nominal Capacity Litres	Effective Gas vol. Litres	Work press. bar	Max Flow Rate lt/min	Weight Dry Kilo	Dimensions in mm unless stated otherwise and subject to manufacturer's tolerances													
					A Inches	B Inches	C	D	E	F	G	H	J Inches	K	L	M	N	P
04	3.8	207	477	15.00	¼ BSP	⅞ UNF	34	78	455	289	171	74	1¼ BSPF	60	36	39	9	55
04	3.8	345	477	16.00	¼ BSP	⅞ UNF	34	78	455	289	173	74	1¼ BSPF	60	36	39	9	55
04	3.8	420	477	16.00	¼ BSP	⅞ UNF	34	78	455	289	173	74	1¼ BSPF	60	36	39	9	55
10	9.4	207	749	36.00	¼ BSP	⅞ UNF	34	78	575	407	230	70	2 BSPF	76	36	46	9	69
10	9.4	276	749	36.00	¼ BSP	⅞ UNF	34	78	575	407	230	70	2 BSPF	76	36	46	9	69
10	9.4	345	749	54.00	¼ BSP	⅞ UNF	34	78	575	407	243	70	2 BSPF	76	36	46	9	69
10	9.4	420	749	54.00	¼ BSP	⅞ UNF	34	78	575	407	243	70	2 BSPF	76	36	46	9	69
20	18.8	207	749	54.00	¼ BSP	⅞ UNF	34	78	886	718	230	70	2 BSPF	76	36	46	9	69
20	18.8	276	749	54.00	¼ BSP	⅞ UNF	34	78	886	718	230	70	2 BSPF	76	36	46	9	69
20	18.8	345	749	100.00	¼ BSP	⅞ UNF	34	78	886	718	243	70	2 BSPF	76	36	46	9	69
20	18.8	420	749	100.00	¼ BSP	⅞ UNF	34	78	886	718	243	70	2 BSPF	76	36	46	9	69
37	35.2	207	749	100.00	¼ BSP	⅞ UNF	34	78	1407	1239	230	70	2 BSPF	76	36	46	9	69
37	35.2	276	749	100.00	¼ BSP	⅞ UNF	34	78	1407	1239	230	70	2 BSPF	76	36	46	9	69
37	35.2	345	749	152.00	¼ BSP	⅞ UNF	34	78	1407	1239	243	70	2 BSPF	76	36	46	9	69
37	35.2	420	749	152.00	¼ BSP	⅞ UNF	34	78	1407	1239	243	70	2 BSPF	76	36	46	9	69
54	49.2	207	749	138.00	¼ BSP	M50x 1.5	70	66	1922	1766	230	70	2 BSPF	76	36	46	9	69
54	49.2	276	749	138.00	¼ BSP	M50x 1.5	70	66	1922	1766	230	70	2 BSPF	76	36	46	9	69
54	49.2	345	749	220.00	¼ BSP	M50x 1.5	70	66	1980	1824	243	70	2 BSPF	76	36	46	9	69
54	49.2	420	749	220.00	¼ BSP	M50x 1.5	70	66	1980	1824	243	70	2 BSPF	76	36	46	9	69
54	49.2	459	749	220.00	¼ BSP	M50x 1.5	70	66	1980	1824	243	70	2 BSPF	76	36	46	9	69

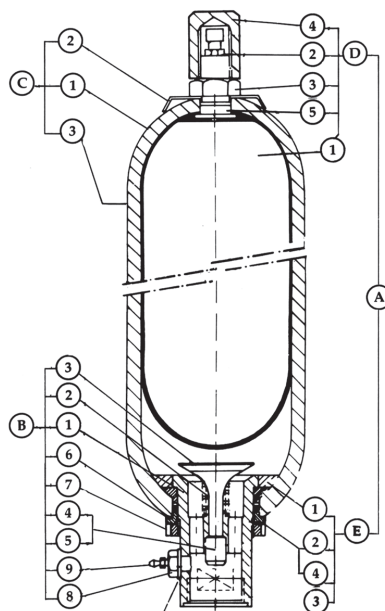
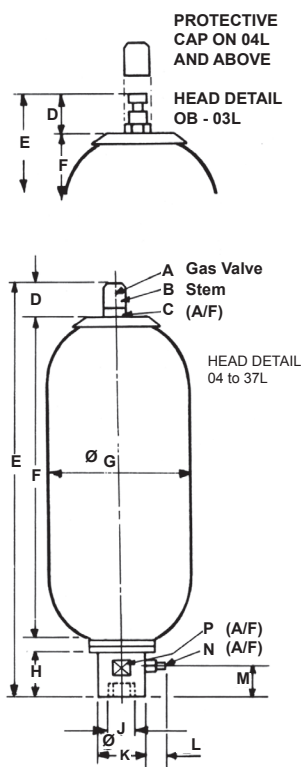

A	Bladder Kit comprising:
D	Bladder assembly
D1	Bladder
D2	Gas valve assembly
D3	Locknut
D4	Protective cap
D5	'O' ring stem
E	Anti extrusion ring assembly
E1	Anti extrusion ring
E2	'O' ring fluid port*
E3	Bonded seal
E4	Back-up ring
B	Fluid port assembly comprising
B1	Fluid port body
B2	Spring
B3	Poppet valve
B4	Collett
B5	Piston
B6	Flanged washer
B7	Locking ring
B8	Bleed adaptor*
B9	Bleed valve*
C	Shell assembly comprising:
C1	Shell
C2	Label
C3	Label warning

*Not fitted on all models

The information in this datasheet is subject to change without prior notice.

ASME Bladder Accumulator

Model numbers

54 - 0 - 0A - 00 - 20 - 4

Nominal Volume - Litres

Bladder Material

- 0 = Nitrile Standard
- 1 = Butyl
- 2 = Low Temperature Nitrile
- 3 = Low permeability
- 6 = Viton
- 8 = High Temperature Nitrile

Bladder stem/ Gas valve

- 0A = 1/4" BSP Gas Valve, Carbon Steel Trim
- SA = 1/4" BSP Gas Valve, St. Steel Trim
- 3F = 1/4" BSP St. Steel Gas Valve, St. Steel Trim

Shell and Fluid port options

207/276 bar

- 00 = Oil Service
- 02 = Low/medium corrosive service
- W6 = Stainless steel externals, unlined shell
- 13 = As "00" except NPT Female conn.
- 14 = AS "02" except NPT Female conn.

345/420 bar

- FJ = Oil Service
- FH = Low/medium corrosive service
- FS = As "W6" except NPT Female conn.
- FR = As "FJ" except NPT Female conn.
- FQ = As "FH" except NPT Female conn.

Maximum Working Pressure

- 20 = 207 bar (3,000 psi)
- 27 = 276 bar (4,000 psi)
- 34 = 345 bar (5,000 psi)
- 42 = 420 bar (6,000 psi)
- 45 = 459 bar (6,666 psi)

Design standard/Authority Approval

- 4 = ASME VIII - 'U' coded
- CE marking of ASME accumulators possible - contact us.