

# Clamps & Brackets

## Specification

### Clamps



Designed to allow quick and easy installation of accumulators, the clamps and bracket assemblies are available to fit accumulator capacities shown below.

Fawcett Christie accumulator clamps are fabricated from stainless steel, brackets from carbon steel and come complete with rubber cushion mouldings. Each assembly is supplied with mounting bolts.

Nitrile rubber mouldings fitted to the supports give rigid mounting to the accumulator and eliminate any vibration and noise.

Diagram A

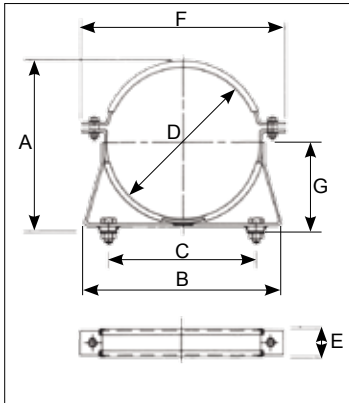

Diagram B

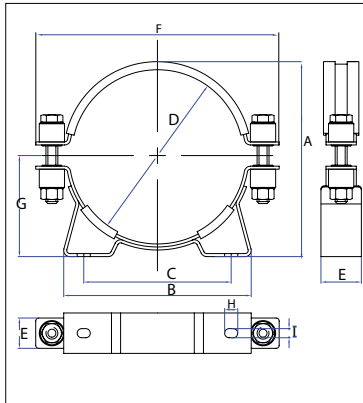
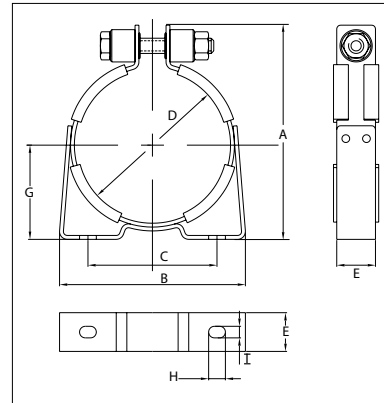

Diagram C



Model Number	Diagram	Accumulator Capacity (L)	Dimensions									Mounting Bolts	Mass (kg)
			A	B	C	D	E	F	G (ref)	H	I		
10957	C	0.6	143	127	90	96	30	-	60	13	9	M8 x 30	0.59
10981*	C	1 - 3	137	144	100	111-116	30	-	73	13	9	M8 x 80	0.75
10982*	B	4 - 9	190	186	146	170	30	244	100	13	9	M8 x 80	1.25
10983*	B	10 - 54	250	267	211	218-228	40	306	129	21	15	M12x80	1.50
11060	A	10 - 54 HP200	270	280	220	252-257	40	345	140	10.5	10.5	M10 x 50	2.00

\* Recently superseded. Previous part details:-

Model Number	Diagram	Accumulator Capacity (L)	Dimensions							Mounting Bolts	Mass (kg)
			A	B	C	D	E	F	G (ref)		
10958 superseded by 10981	C	1 - 3	140	165	120	112-114	34	165	72	M10 x 30	0.71
10959 superseded by 10982	B	4 - 9	200	190	148	165-168	34	250	100	M10 x 30	0.91
10960 superseded by 10983	B	10 - 54	263	295	195	220-230	40	295	134	M10 x 45	1.50

## Brackets

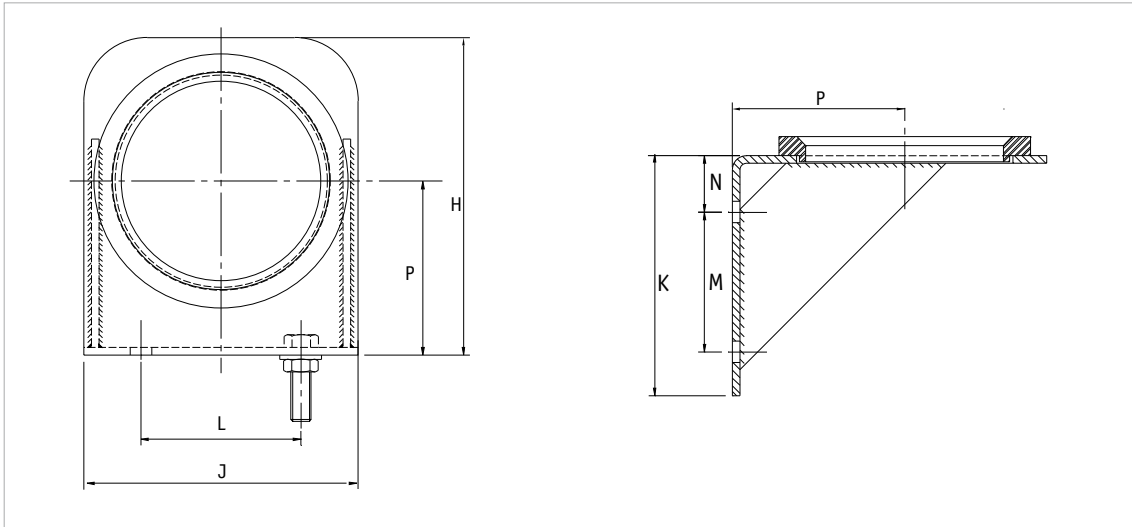

Brackets are manufactured from carbon steel

Mounting bolts - M16 X 70

Spare cushion rings

**Support bracket assembly** (c/w cushion ring)

4 to 9L part number: 48472-A00

10 to 54L part number: 48473-A00

Model Number	Accumulator Capacity (L)	Dimensions									Mass
		H	J	K	L	M	N	P	Q	R	
10962	4 - 9	185	165	150	85	85	40	102	17	6	2.5 kg
10961	10 - 54	250	216	191	108	111	45	130	17	6	6kg