



## Specification

### Capabilities

FCH Piston Accumulators are available in any capacity up to 1350 litres. Capacity is only limited by pressure and available materials. Our standard range is 1 litre up-to and including 150 litres. All units are made to order, and can be custom engineered to suit specific space restrictions.

### Pressure

Piston Accumulators are available in any pressure between 5 bar and 2500 bars. The pressure rating is dependant on capacity and/or available materials.

### Materials

Our units are available in a variety of materials such as Carbon steel, Stainless steel, Duplex or Super Duplex steels and Aluminium. All come with a choice of material certification options.

### Design

Vessels will be in accordance with the PED 97/23/EC for use in Europe and designed to PD5500. Optional 3rd party witness (eg. Lloyds) available. Other design codes can be considered for example ASME VIII Div 1.

### Fluid End Connections

To suit customer requirements – e.g. NPT, BSP, Autoclave type or SAE/ASME flanged.

### Gas End Connections

To suit customer requirements – e.g. NPT, BSP, Autoclave type or SAE/ASME flanged. Transfer barrier ports, Gas Charging valves (brass and stainless) Gas pressure relief devices e.g. Burst discs and Fuse plugs.

### Seals

For low or high temperature applications. Materials typically Nitrile, PTFE, Viton, EPDM and others.

### Piston Position Indicators

Carbon Steel Options:

- Tailrod – magnetic operation with visual flapper or magnetic indicator switch.
- Bent tube Indicator - magnetic operation with visual flapper or magnetic indicator switch.
- Tailrod – operating a cam/switch.
- Proximity switch

Stainless Steel Options:

- Piston Magnet - magnetic operation with visual flapper or magnetic indicator switch
- Proximity switches



## Carbon Steel Units

Design Pressure (PS)	Internal Diameter (Ø d)											
	50	80	100	125	160	200	250	280	320	400	501	600
150												
170												
200												
220												
240												
250												
270												
275												
280												
300												
350												
370												
390												
450												
455												
490												
530												
760												
863												
950												
1035												
1050												
1380												
1500												
2100												

Due to our wide range of product sizes we are unable to display every option available therefore the adjacent table displays a selection of our most commonly requested sizes.

For further information please contact a member of our sales team.

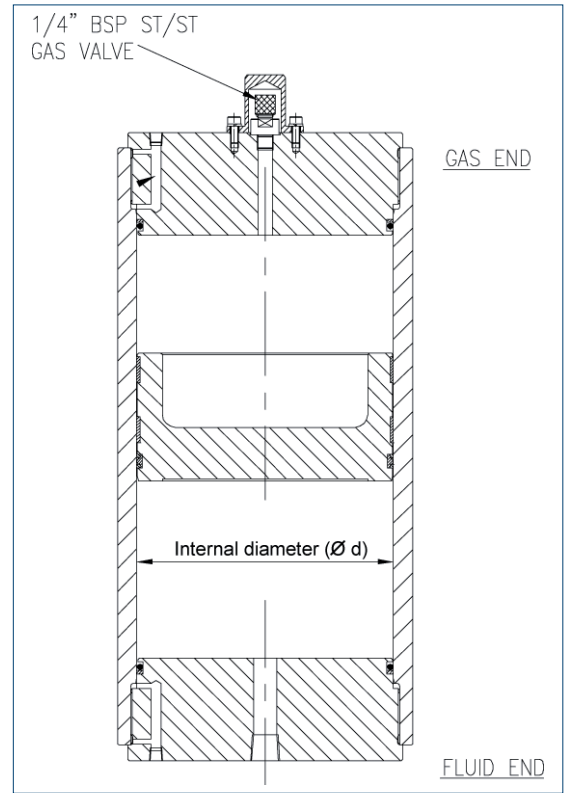

## Stainless Steel (17/4 PH)

Design Pressure (PS)	Internal Diameter (Ø d)											
	50	80	100	125	160	200	250	280	320	400	501	600
455												
600												
690												
760												
863												
960												
1050												
1380												
1500												
2100												

## Stainless Steel (AISI 316)

Design Pressure (PS)	Internal Diameter (Ø d)											
	50	80	100	125	160	200	250	280	320	400	501	600
150												
220												
230												
250												
320												
350												
425												
455												
550												
630												
750												
760												



THE OLAER GROUP: **AUSTRALIA** Olaer FCH. Tel. +61 2 9981 6888. **AUSTRIA** Olaer Austria GmbH. Tel: +43 7229 80306. **BELGIUM** S.A. Olaer Benelux Tel: +32 2 466 15 15. **CZECH REPUBLIC** Olaer CZ s.r.o. Tel: +42 5 47125 601-8. **DENMARK** Oiltech DK. Tel: +45 86 69 20 38. **FINLAND** Oiltech Hydraulics OY. Tel: +358 9 413 755 00. **FRANCE** Olaer Industries S.A. Tel: +33 1 4119 1700. **GERMANY** Olaer Industries GmbH. Tel: +49 6842 9204-0. **HOLLAND** Olaer Nederland B.V. Tel: +31 76 5412453. **INDIA** FCH India Tel: + 91 80 28437690 91. **ITALY** Olaer Italiana S.p.A. Tel: +39 011 9918511. **KOREA** Hyundai Olaer Hydraulic Co. Tel: +82 31 499 0897. **NORWAY** Oiltech AS. Tel: +47 64 91 1180. **POLAND** Oiltech Polska Tel: +48 22 6738162. **SOUTH AFRICA** FCH c/o Rolton Products CC. Tel: +27 11 474 3095. **SPAIN** Olaer-Oiltech Iberica SAU Tel: +34 933 368 900. **SWEDEN** Oiltech AB. Tel: +46 8 636 07 00. **SWITZERLAND** Olaer (Schweiz) AG. Tel: + 41 26 492 70 00. **UK** FCH Ltd. Tel: +44 1244 535515. **USA** Oil Air Hydraulics Inc. Tel: +1 713 937 89 00.