

Accumulator

High-pressure diaphragm accumulator
conforming to EC regulations

ELM Range

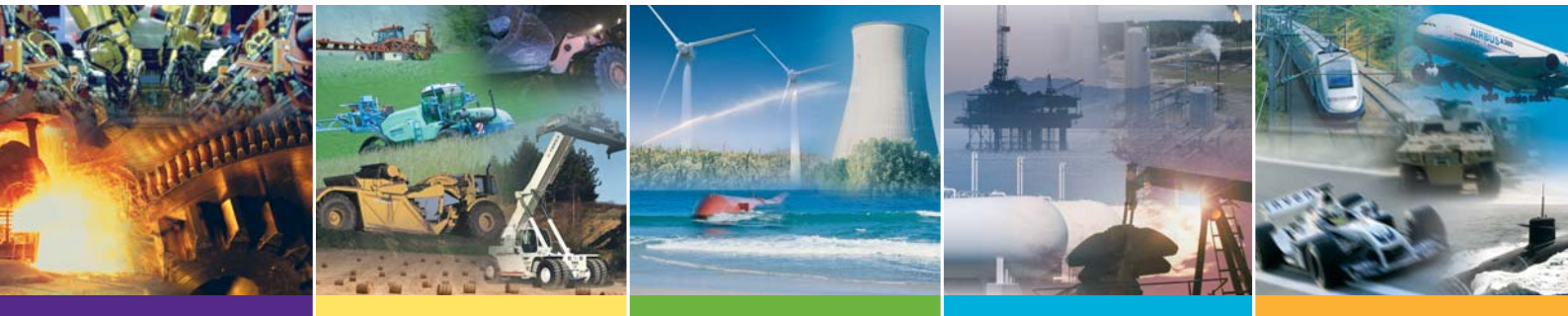

The Professional Choice



Day to day, the agricultural, forestry, construction and public works sectors are faced with the fundamental question :

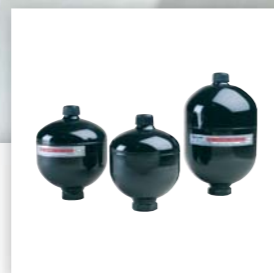
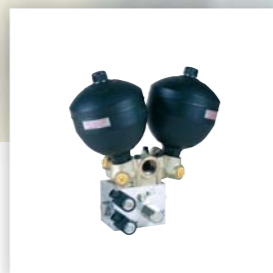

How to enhance driver and vehicle comfort ?

Thanks to our comprehensive range of diaphragm accumulators, we offer our customers flexibility of driving and record speeds while guaranteeing enhanced machinery longevity

The accumulator offers the possibility of extending the range of use of your machine and tools.

Don't wait any longer; you can be a winner by standardizing the EC regulation compliant diaphragm accumulator on your machines.

Comparative cycle for a tractor and its accessories in working conditions

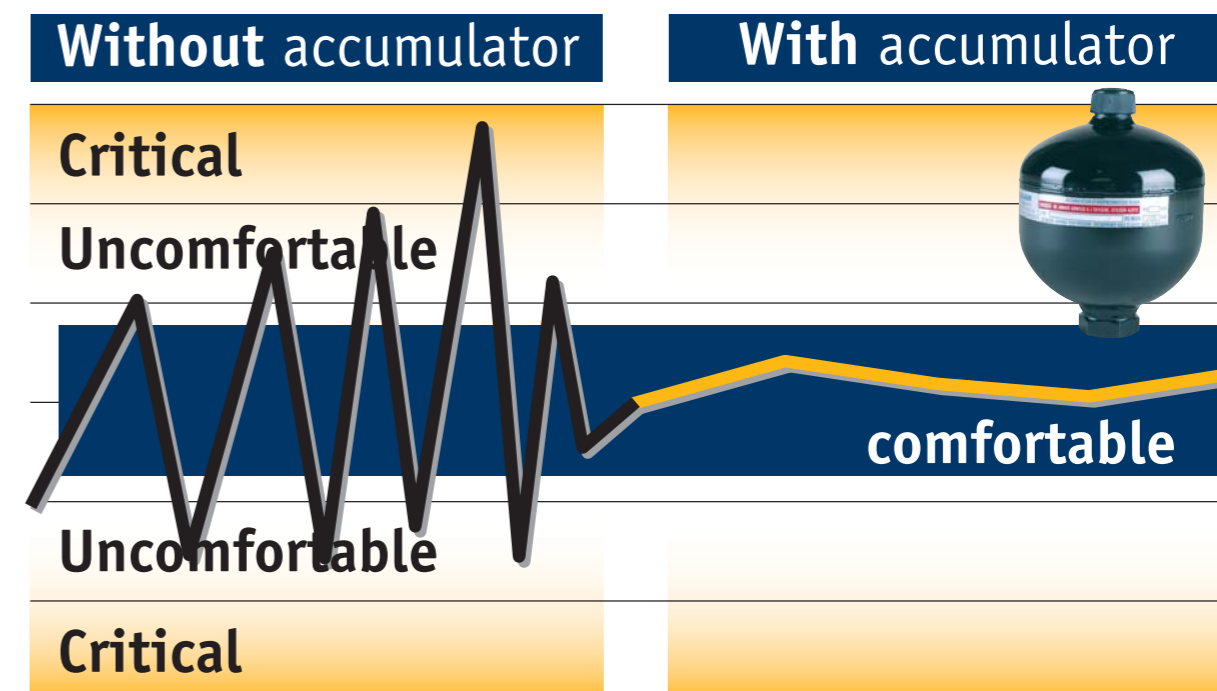

*Study carried out in cooperation with one of the largest manufacturers of agricultural machinery



Speed 50 kph



Load variation on front axle from 3,5 à 100 %



An eloquent example* of application

Faced with difficult working conditions, a farm supervisor wants to **increase his driving comfort and reduce breakage** among his fleet of machines.

OPERATING PRINCIPLE

Due to the compressibility of the gas, nitrogen, the diaphragm accumulator enables to store, stock and return a liquid under pressure.

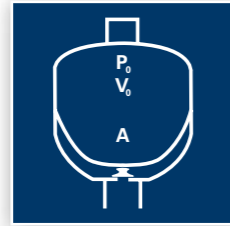

A - The diaphragm is in the precharge position, which means that it is only filled with nitrogen. The knob closes the hydraulic orifice and prevents the destruction of the diaphragm.

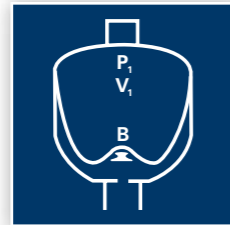

B - Position at the minimum operating pressure : there must be a certain amount of fluid between the diaphragm and the hydraulic orifice, such that the knob does not close the hydraulic orifice. Thus, P0 must always be < P1.

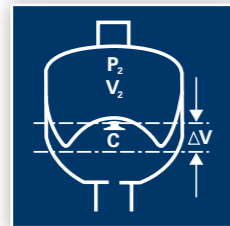

C - Position at the maximum operating pressure: the volume change Delta V between the minimum and maximum positions of the operating pressures represents the fluid quantity stored.

- V0** = Capacity in nitrogen of the accumulator
- V1** = Gas volume at the minimum hydraulic pressure
- V2** = Gas volume at the maximum hydraulic pressure
- ΔV** = Returned and/or stored volume between P1 and P2
- P0** = Initial preload of the accumulator
- P1** = Gas pressure at the minimum hydraulic pressure
- P2** = Gas pressure at the maximum hydraulic pressure

THE BENEFITS FOR YOU

The adaptation of a hydraulic shock absorber made up of a diaphragm accumulator improves driver comfort and offers immediate response times when driving over obstacles and the same flexibility for variable operating conditions.

- 0 < speed < 50 kph
- 3.5 < load variation < 100%
- Identical flexibility depending on your use.

The same EC regulation compliant accumulator can be used in over 35 destination countries, thus facilitating their free movement.

TECHNICAL CHARACTERISTICS

The technical characteristics are as follows:

Minimum/maximum temperature allowable (° Celsius) : - 10/+80

Materials : steel casing, nitrile diaphragm or bladder depending on model, for other constructions :

consult OLAER.



Olaer has developed highly advanced calculation software applications designed to simulate the operation of accumulators in terms of water hammer arresting, pulsation dampening, thermal expansion, and energy storage. These software applications are available on CD-ROM and on our website: www.olaer.com.

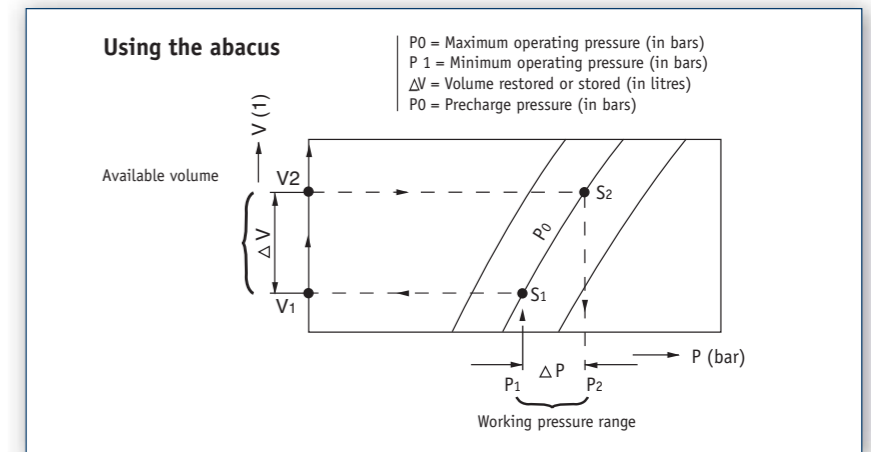

This abacus can be used, on the basis of the arrangement of the various parameters, to determine the volume of oil available, the size of the accumulator or the pressures. It does not take account of the correction for actual compressibility of the real gas, the actual adiabatic coefficient or the polytropic coefficient of the application. Depending on the conditions of use, these can have a significant effect and may entail the need for certain corrections.

- We recommend**
- In load dampening configuration : P0 = 0,6 à 0,9 Pm (Pm = average working pressure)
 - Pulsation dampening : P0 = 0,6 à 0,8 Pm (Pm = average working pressure)
 - Energy storage : P0 = 0,9 P1 (P1 = minimum working pressure)

***REMINDER**

Isothermal : The conversion is referred to as isothermal when the compression or expansion of the gas occurs slowly to allow for heat exchange so as to maintain a constant temperature

Adiabatic : The conversion is referred to as adiabatic when the compression or expansion occurs rapidly without exchange of heat with the ambient surroundings.

ENERGY STORAGE CALCULATION ABACUS

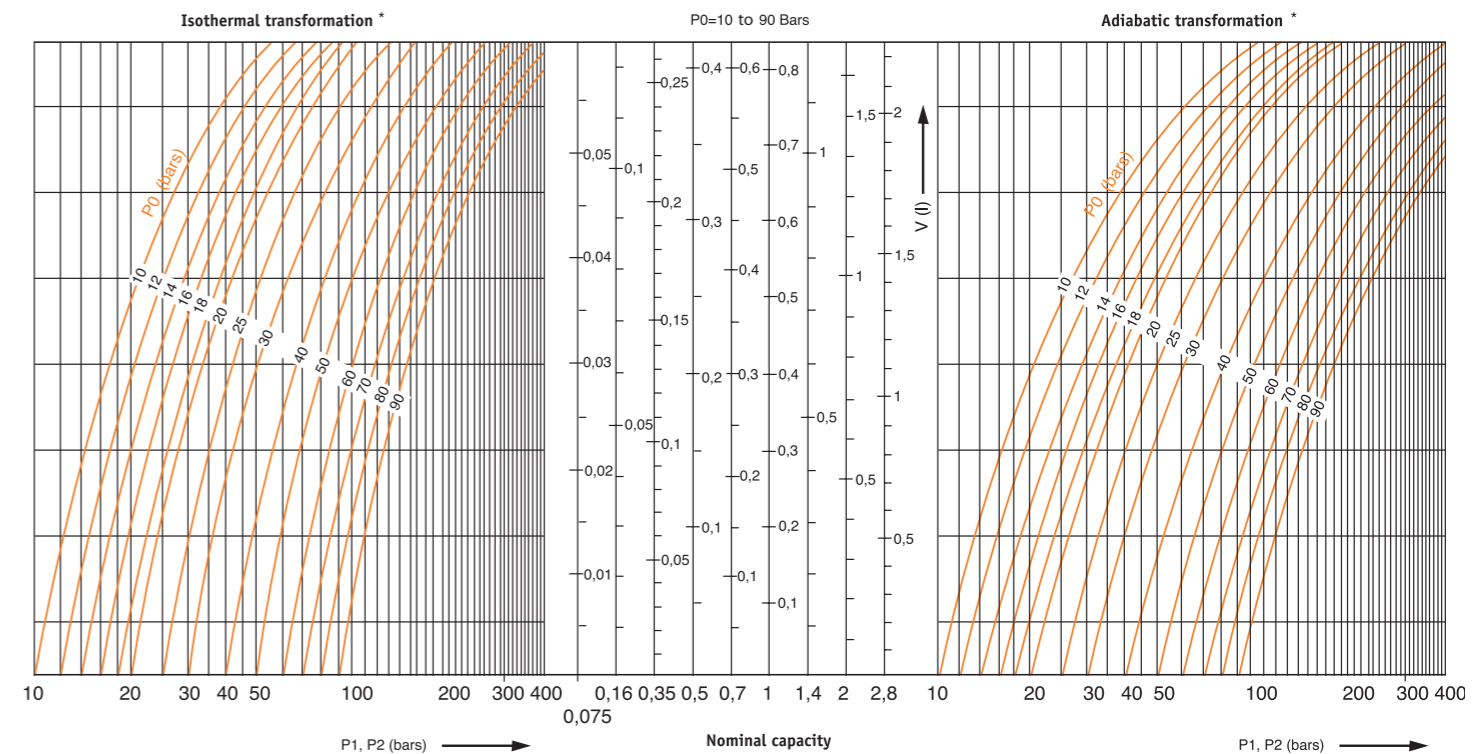

Technical characteristics

Form A

Standart F execution
nitrogen rechargeable

G execution at request
nitrogen pre-charged in factory

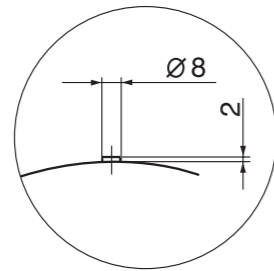
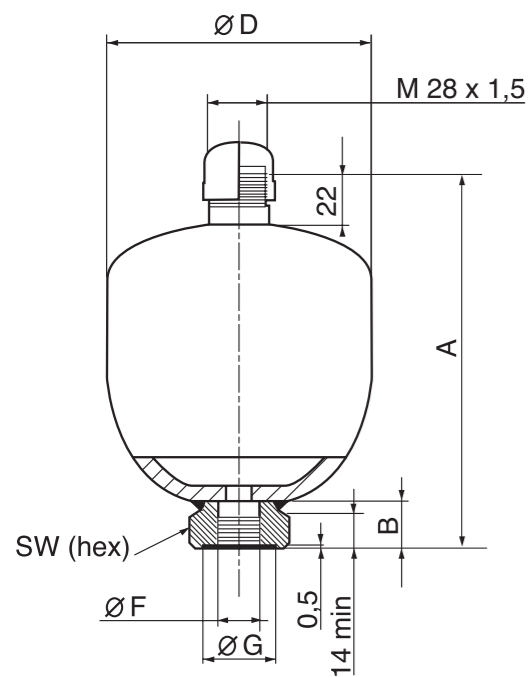

Form C

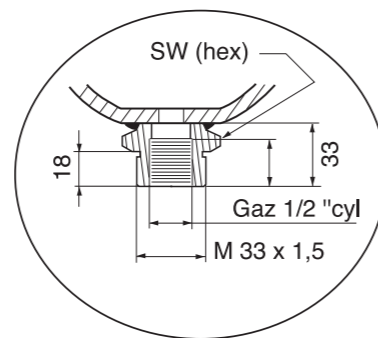

Other connection
at request



Designation	Execution Form	Volume V0 in litres	Max pressure in bar	Max precharge pressure in bar	Compression ratio P max/P0	Pressure amplitude P max / P mini	Weight in kg	A	B	SW	D	G	F	H	Oilport	Clamp designation	Lock-nut designation
ELM 0.075-250/00/AF	AF	0,075	250	130	8	210	0,7	111	20	32	64	29	G 1/2	-	-	-	-
ELM 0.16-250/00/AF	AF	0,16	250	130	6	210	1	120	20	32	75	29	G 1/2	-	-	-	-
ELM 0.32-210/00/AF	AF	0,32	210	130	8	140	1,4	134	20	32	93	29	G 1/2	-	E95	-	-
ELM 0.50-210/00/AF	AF	0,50	210	130	8	175	2	152	22	41	106	34	G 1/2	-	E106	-	-
ELM 0.50-210/00/CF	CF	0,50	210	130	8	175	2	163	33	41	106	-	G 1/2	M33x1,5	E106	M33	-
ELM 0.75-160/00/CF*	CF	0,75	160	130	8	120	2,6	176	33	41	121	-	G 1/2	-	E124	-	-
ELM 0.75-210/00/AF	AF	0,75	210	130	8	175	2,6	166	22	41	122	34	G 1/2	-	E124	-	-
ELM 0.75-210/00/CF	CF	0,75	210	130	8	175	2,6	177	33	41	122	-	G 1/2	M33x1,5	E124	M33	-
ELM 0.75-350/00/AF	AF	0,75	350	130	8	150	4,4	168	18	41	133	34	G 1/2	-	E136	-	-
ELM 0.75-350/00/CF	CF	0,75	350	130	8	150	4,5	189	18	41	133	-	G 1/2	M33x1,5	E136	M33	-
ELM 1-210/00/AF	AF	1	210	130	8	170	3,5	180	22	41	136	34	G 1/2	-	E136	-	-
ELM 1-210/00/CF	CF	1	210	130	8	170	3,5	191	33	41	136	-	G 1/2	M33x1,5	E136	M33	-
ELM 1.4-210/90/AF	AF	1,4	210	130	8	120	4,2	191	22	41	148	34	G 1/2	-	E147	-	-
ELM 1.4-210/90/CF	CF	1,4	210	130	8	120	4,2	202	33	41	148	-	G 1/2	M33x1,5	E147	M33	-
ELM 1.4-350/90/AF	AF	1,4	350	130	8	150	7,4	199	20	41	160	34	G 1/2	-	-	-	-
ELM 1.4-350/90/CF	CF	1,4	350	130	8	150	7,5	220	20	41	160	-	G 1/2	M33x1,5	-	-	M33
ELM 2-100/90/AF	AF	2	100	100	8	80	3,5	240	22	41	144	34	G 1/2	-	E147	-	-
ELM 2-250/90/AF	AF	2	250	130	8	140	7,5	251	22	41	155	33	G 3/4	-	E155	-	-
ELM 2-350/90/AF	AF	2	350	130	8	200	11,3	219	22	55	180	34	G 3/4	-	E180	-	-
ELM 2-350/90/CF	CF	2	350	130	8	200	11,5	240	22	55	180	-	G 3/4	M45x1,5	E180	M45	-
ELM 2.8-250/90/AF	AF	2,8	250	130	6	140	10	268	21	41	174	34	G 3/4	-	E174	-	-
ELM 2.8-350/90/AF	AF	2,8	350	130	6	200	14,3	264	21	55	180	34	G 3/4	-	E180	-	-
ELM 2.8-350/90/CF	CF	2,8	350	130	6	200	14,5	285	21	55	180	-	G 3/4	M45x1,5	E180	M45	-
ELM 3.5-250/90/AF	AF	3,5	250	130	4	140	11	307	21	41	174	33	G 3/4	-	E174	-	-
ELM 3.5-350/90/AF	AF	3,5	350	130	4	200	16	304	21	55	180	34	G 3/4	-	E180	-	-
ELM 3.5-350/90/CF	CF	3,5	350	130	4	200	16,5	325	21	55	180	-	G 3/4	M45x1,5	E180	M45	-

Range conform to EC standart group 2
* Stainless stell version

The above measurements are given in mm and do not take manufacturing tolerance into consideration

Accessories



These accessories are designed so that the accumulator can be securely attached in all configurations.

Clamp

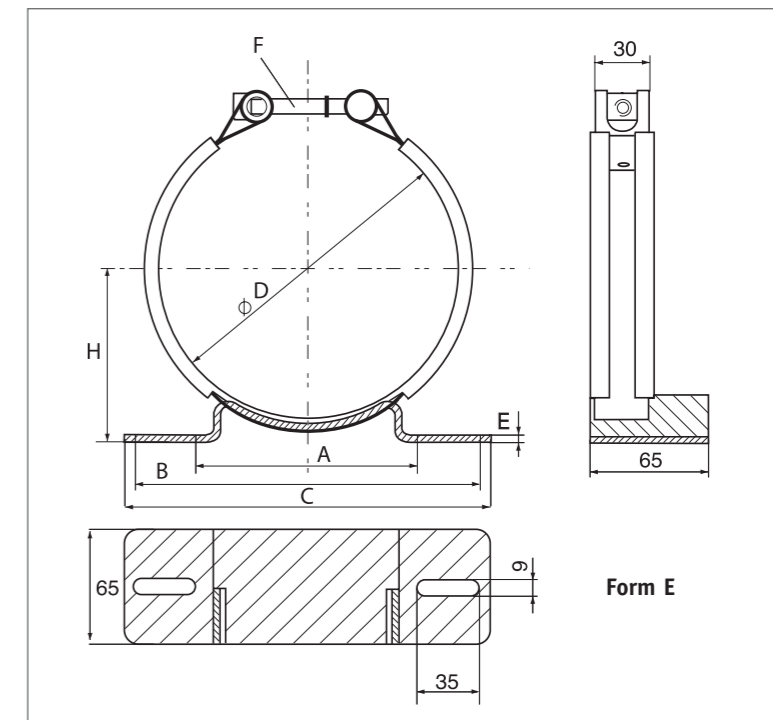

Designation	Holding diameter mini - maxi	A	B	C	D	E	H	MxL
E95	93 à 97	78	148	160	95	3	66,5	M10x65
E106	104 à 108	78	148	160	106	3	72	M10x65
E124	121 à 125	78	148	160	121	3	77,5	M10x65
E136	130 à 136	78	148	160	136	3	83,5	M10x80
E147	143 à 149	78	148	160	149	3	90	M10x80
E155	153 à 157	128	198	210	155	4	90,7	M10x80
E174	171 à 177	128	198	210	174	4	100,7	M10x100
E180	178 à 184	128	198	210	180	4	105	M10x80

Range conforms to EC standard group 2

Lock-nut

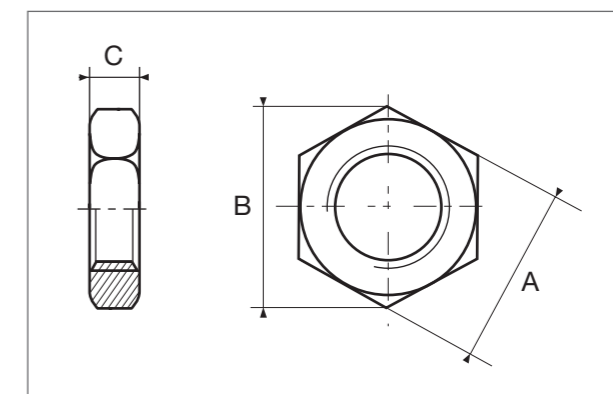

Designation	Pitch	A	B	C
M 33	1,5	50	57,5	10
M 45	1,5	70	80,8	10

The above measurements are given in mm and do not take manufacturing tolerance into consideration



CHARGING AND GAUGING ASSEMBLY

Suitable for use with all accumulators, the charging and gauging assembly is designed to check, fill and bleed nitrogen. It is screwed onto the filling valve, and connected via a hose to the pressure regulator valve fitted onto the nitrogen source.

VGU MODEL

The universal charging and gauging assembly (VGU) is designed for use with all accumulators on the market

Technical characteristic

Maximum operating pressure : 340 bars

How to order ?

Example:
VGU/F 25/250 7 TS2 3 25/250 = possible choice of pressure gauges depending on the pressure ranges 6/10/25/60/100/160/250/400

Optional, at request

Adapters for foreign nitrogen cylinders, specify the country
Hoses of different lengths
Connection for specific filling valve.



ISOLATION AND DECOMPRESSION BLOCKS

These appliances are designed to bring together, on a single compact block, all the components necessary for the operation of a hydraulic installation fitted with hydro-pneumatic accumulators.

The functions they perform include manual and/or electric decompression, isolation, flow regulation and pressure limitation.

Various nominal passage diameters: 10 mm (DI 10 block), 16 mm (DI 16 block), 20 mm (DI 20 block), 24 mm (DI 24 block), 32 mm (DI 32 block).

Maximum operating pressure from 330 to 550 bars depending on the model. **Contact us at Olaer** for our documentation and selection program.



FUNCTION BLOCKS

Olaer has a broad range of function blocks adapted to your specific use. Contact our technical department for further information.

ORDERING ACCUMULATOR

ELM 0,75 - 350/00/AF 01125 P0=90b

Accumulator series

European range of ELM diaphragm accumulators

Volume

in litres

Maximum operating pressure

in bar

Regulation code

00 : EC regulations for volumes ranging from 0.075 to 1 l.
90 : EC regulations for volumes ranging from 1.4 to 3.5 l.

Form

A : internal tapped outlet
C : internal tapped end external threaded outlet

Execution

F : Standard (nitrogen rechargeable)
G : At request (precharged with nitrogen in factory)

Construction

Mineral oils, operating temperature from -10 to + 80 °C, construction 01125 (standard construction). Other fluids and temperatures, **contact Olaer**

Nitrogen precharge pressure

in bar at 20° C

(See calculation abacus on page 5 or contact the Olaer Group technical departments)

ORDERING ACCESSORIES AND PERIPHERALS

Indicate the designation of the accessories mentioned in the tables on page 7 and peripherals on page 8.



Before installing the accumulator, it is essential to perform a visual inspection to detect any damage. For optimum operation, the accumulator should be placed as closely as possible to the operating device or to be protected. The ELM can be mounted vertically, feeling valve at the top, or horizontally.

- Do not stand in front of the openings
- Keep an eye on the environmental conditions and, if need be, protect the accumulator from sources of heat, electrical fields, magnetic fields, lightning, humidity and the bad weather
- Leave a space of 200 mm above the filling valve for connecting it to the gauging and charging assembly
- Preserve accessibility with the bleed hole
- Ensure that the markings are visible
- Install it in a manner that ensures that the pipes directly or indirectly attached to it are not subject to any abnormal stress
- Place the body of the accumulator on a support or surround it by a guard capable of preventing it from moving or of limiting its movement.
- Connect the accumulator to the hydraulic circuit by means of the appropriate connecting devices, such as unions and flanges
- Make sure that the fluid is compatible with the equipment
- Make sure that the maximum allowable pressure of the accumulator is equal to or greater than that of the hydraulic circuit
- Ensure that the temperature and pressure limits are complied
- Fit the hydraulic circuit with a pressure limiting system
- If necessary, make provision for a rupture disk or relief valve to cover the risk of excess pressure linked to thermodynamic phenomena
- To envisage a filter on the hydraulic system and/or to carry out inspections intern as frequent as necessary in the employment case of an abrasive fluid.

IT IS STRICTLY FORBIDDEN TO

- Weld, rivet or screw any part onto the accumulator
- Carry out any operation which could affect the mechanical properties of the accumulator
- Use the accumulator as a construction part: it should not support any constraint or load
- Modify the accumulator without the prior agreement of the manufacturer.

COMMISSIONING

For commissioning, see the instructions delivered with the accumulator.

Extract from European legislation.

Directive 97/23/ EC is applicable from

29-11-1999 and mandatory from 29-05-2002.

WHAT YOU NEED TO KNOW

Decree 99-1046, which applies to new machinery and the ministerial order of 15-03-2000, which applies to the operation of all machinery, transposed the directive into French domestic legislation.

- **Free movement of machinery within the European Union.**
- **Group 2 fluid accumulators whose V ≤ 1 L and PS ≤ 1000 bar are not entitled to bear EC marking.**
- **The EC marking should be accompanied by the identification number of the notified authority.**

EC type accumulators are delivered with **instructions for operation** and a **declaration of conformity**.

Olaer designs and manufactures hydro-pneumatic accumulators for use in all countries and which comply with national regulations in force as ASME / selo...

Acting in accordance with the procedure laid down in Article 187b of the Treaty⁽¹⁾, in the light of the joint text approved by the Conciliation Committee on 4 February 1997,

1. Whereas the internal market is an area without internal frontiers in which the free movement of goods, persons, services and capital is ensured;
2. Whereas there are differences in the content and scope of the laws, regulations and administrative provisions in force in the Member States with regard to the safety and protection of health of persons and, where appropriate, domestic animals or property, where pressure equipment not covered by present Community legislation is concerned, whereas the certification and inspection procedures for such equipment differ from one Member State to another; whereas such disparities may well constitute barriers to trade within the Community;
3. Whereas the harmonization of national legislation is the only means of removing these barriers to free

⁽¹⁾ OJ No C 244, 9. 9. 1993, p. 1 and OJ No C 207, 27. 7. 1994, p. 3.
⁽²⁾ OJ No C 32, 19. 2. 1994, p. 10.
⁽³⁾ Opinion of the European Parliament of 19 April 1994 (OJ No C 128, 9. 5. 1994, p. 41), common position of the Council of 29 March 1994 (OJ No C 147, 21. 5. 1994, p. 3), Decision of the European Parliament of 17 July 1994 (OJ No C 261, 9. 9. 1994, p. 48), Council Decision of 17 April 1997.

4. Whereas it is more than due to provide by any of the Community equipment PS exceeding 0,7 bar;
5. Whereas this Directive relates also to assemblies composed of several pieces of pressure equipment assembled to constitute an integrated and functional whole; whereas these assemblies may range from simple assemblies such as pressure cookers to complex assemblies such as water-tube boilers; whereas, if the manufacturer of an assembly intends it to be placed on the market and put into service as an assembly — and not in the form of its constituent non-assembled elements — that assembly must conform to this Directive; whereas, on the other hand, this Directive does not cover the assembly of pressure equipment on the site and under the responsibility of the user, as in the case of industrial installations;
6. Whereas this Directive harmonizes national provisions on hazards due to pressure; whereas the other hazards which this equipment may present accordingly may fall within the scope of other Directives dealing with such hazards; whereas, however, pressure equipment may be included among products covered by other Directives based on Article 100a of the Treaty; whereas the provisions laid down in some of those Directives deal with the hazard due to pressure; whereas those provisions are considered adequate to provide appropriate protection where the hazard due to pressure associated with such equipment remains

Australia

Olaer Fawcett Christie PTY Limited
13 Boola Place
Cromer NSW 2099 Australia
Tel : + 61.2.9981.6888
Fax : + 61.2.9981.6144
E-mail : info@olaer.com.au
www.olaer.com.au

Austria

Olaer Austria GmbH
Wachtelstraße 25
A-4053 Haid
Tel : + 43.7229.80306
Fax : + 43.7229.80306-21
E-mail : info@olaer.at
www.olaer.at

Belgium

S.A. Olaer Benelux N.V.
Z3, Doornveld 21
B-1731 Zellik
Tel : + 32 2 466 15 15
Fax : + 32 2 466 16 24
E-mail : info@olaer.be
www.olaer.be

China

Olaer Tianjin Hydraulic
Manufacturing Company Ltd
11-A Jimei Industrial Zone
XI QING Economic Development Area
Tianjin - 300 385 CHINA
Tel : + 86 22 2 3889096
Fax : + 86 22 2 3889097
E-mail : olaer@olaer.net.cn
www.olaer.net.cn

Oiltech Hydraulic Manufacturing
(Suzhou) CO, LTD
No.2 workshop, #95 WeiXin Road,
Weiting, Suzhou, Jiangsu, P.R. China
215121
Tel : + 86-512 6289 1000
Fax : + 86-512 6289 0805

Czech Republic

Olaer CZ s.r.o.
Videnská 125
CZ - 61900 BRNO
Tel : + 420 5 4712 5601-10
Fax : + 420 5 4712 5600
E-mail : info@olaer.cz
www.olaer.cz

Denmark

Oiltech AB
Hestehøjvej 1
DK - 9632 MØLDRUP
Tel : + 45.86.69.20.38
Fax : + 45.86.69.23.38
E-mail : oiltech@oiltech-olaer.dk
www.oiltech-olaer.dk

Finland

Oiltech Hydraulics Oy
Veneentekijäntie 2, PI 190
FI-00210 Helsinki
Tel : + 35 8 9 4137 5500
Fax : + 35 8 9 4137 5500
E-mail : info@oiltech.fi
www.oiltech.fi

France

Olaer Industries SA
16 rue de Seine
F-92704 Colombes Cedex
Tel : + 33.01.41.19.17.00
Fax : + 33.01.41.19.17.20
E-mail : olaer@olaer.com
www.olaer.fr

Germany

Olaer Industries GmbH
Zum Gunterstal 4
D - 66440 Blieskastel
Tel : + 49.(0) 6842 92040
Fax : + 49.(0)6842 9204-15
E-mail : info@olaer.de
www.olaer.de

Holland

Olaer Nederland BV
De Lind 10, Postbus 75
NL-4840 AB Prinsenbeek
Tel : + 31 76-5412453
Fax : + 31 76-5411502
E-mail : info@olaer.nl
www.olaer.nl

Hungary

Szalézi út 13/B
H - 2509 Esztergom Hungary
Tel : + 36 (70) 943 8114
Fax : + 36 (33) 319 954
Email : zsold.spednel@olaer.hu
www.olaer.hu

India

Coolers & heatexchangers
Olaer Fawcett Christie Hydraulics
(India) Private Limited No. 29/1&2,
Chunchagatta Road, Konanakunte
post,
Bangalore - 560062
Tel : 28437690, 91
Fax : 080-28437799, 26611716
E-mail : info@olaer.in
www.olaer.in

Accumulators

Fawcett Christie Hydraulics (I) pvt. Ltd.
No. 21/C, 1st Phase, Kiadb
Kumbalgod Industrial area, Mysore
highway,
Bangalore - 560074 - India
Tel : 28437690, 91
Fax : 080-28437799, 26611716
E-mail : info@olaer.in
www.olaer.in

Indonesia

Olaer Fawcett Christie
Jl Lembong No 42 Bandung
Jawa Barat 40111
INDONESIA
Mob : + 62 81 320 94 8833

Italy

Olaer Italiana S.p.A.
Strada Fantasia 83
IT - 10040 Leini (Torino)
Tel : + 39 011 991.85.11
Fax : + 39 011 998.02.02
E-mail : anna.cinque@olaer.it
www.olaer.it

Korea

Hyundai Olaer Hydraulic Co. Ltd
3Ba 204-1 Shihwa Industrial Complex
Jeongwang-dong, Siheung-si
Gyeonggi-do 429-450 KOREA
Tel : + 82.31.499.0797
Fax : + 82.31.499.2249
E-mail : master@hyundaiolaer.co.kr
www.hyundaiolaer.co.kr

Norway

Oiltech AS
Dynamitveien 23, PB 133
NO-1401 Ski
Tel : + 47 64 91 11 80
Fax : + 47 64 91 11 81
E-mail : oiltech@oiltech.no
www.oiltech.no

Poland

Oiltech Polska
ul. Gen Bora Komorowskiego 22
PL-03982 WARSZAWA
Tel : + 48 22 6738162
Fax : + 48 22 6738163
krysztof.klepka@oiltech.se
www.oiltech.pl

Singapore

Olaer Singapore
Blk 823, 25 Loyang Crescent
Loyang Offshore Supply Base
Singapore 508988
Tel : + 65 65420278
Fax : + 65 65421083

Slovakia

OLAER
Josef Mezaros
Lotysska 22
SK - 821 06 BRATISLAVA
Slovensko
Tel : + 0421 2 4552 1154
Fax : + 0421 2 4552 1154
E-mail : mesaros@olaer.sk
www.olaer.sk

South Africa

Rolton Products (Pty) Ltd
43 Spokeshave Street
Stormill Ext 2 Po Box 43244
Industria 2042 1725 Roodeport
South Africa
Tel : + 27(0)11 474.3095/6
Fax : + 27(0)11.474.8384
rolton@global.co.za
www.rolton.edx.co.za

Spain

Olaer Oiltech Iberica S.A.U.
Travesia Industrial 29
08907 L'Hospitalet de Llobregat
E-Barcelona
Tel : + 34.933.368.900
Fax : + 34.933.357.186
E-mail : olaer@olaer.es
www.olaer.es

Sweden

Oiltech AB
Postbox 10012 Förrådsvägen 2
SE-181 10 Lidingö
Tel : + 46 8 636 07 00
Fax : + 46 8 767 97 56
E-mail : info@oiltech.se
www.oiltech.se

Switzerland

Olaer (Schweiz) AG
Bonustrasse 3 CH-3186 Düringen
Tel : + 41 26 492 70 00
Fax : + 41 26 492 70 70
E-mail : info@olaer.ch
www.olaer.ch

UAE

The Kanoo Group, Oil & Gas Division
PO Box 245, Abu Dhabi
United Arab Emirates
Tel : 971 2 6774444
Fax : 971 2 678 5670
E-mail : onseng1@kanoo.co.ae

United Kingdom

Fawcett Christie Hydraulics Ltd
Glendale Avenue
Sandycroft Industrial Estate
Sandycroft - Deeside
Flintshire CH5 2QP
North Wales U.K
Tel : + 44 1244 535515
Fax : + 44 1244 533002
E-mail : sales@fch.co.uk
www.fch.co.uk

United States

OilAir Hydraulics Inc.
11505 West Little York
Houston, Texas 77041
Tel : + 1 713 937-8900
Fax : + 1 713 937-0438
E-mail : info@oilairhydraulics.com
www.oilairhydraulics.com

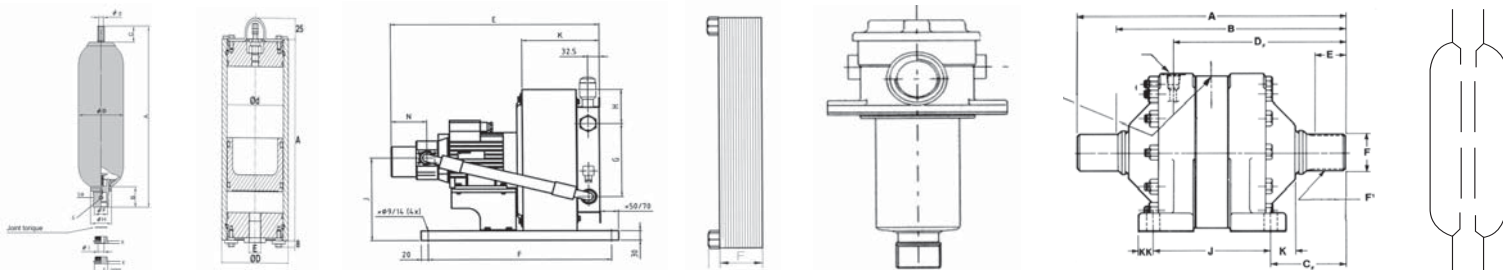

France

Olaer Industries SA
16, rue de Seine
92704 Colombes Cedex
Tél. : + 33 01 41 19 17 00
Fax : + 33 01 41 19 17 20
E-mail : olaer@olaer.com
www.olaer.fr